



Cleanroom-rated Overhead Ionizing Blower

GUARDIAN CR2000

Simco-Ion's Guardian CR2000 Cleanroom-rated Overhead Ionizing Blower is designed specifically for use in cleanroom applications. The Guardian CR2000 features a patented circuit that results in balanced delivery of positive and negative ions, which ensures that the unit will maintain an ion balance of $0 \pm 5V$. Balance stability is further enhanced by the use of Simco-Ion's unique "ion shields" at the fan outputs to reduce parasitic ion loss.

The Guardian CR2000 ensures cleanroom compatibility with all fan and air bearing silicone free surfaces. Fan assemblies are particle-tested to ISO 14644-1 Class 4 (Fed Std. 209E Class 10) particle limits.

The Guardian CR2000 is also equipped with Simco-Ion's patented built-in emitter point cleaner. A lockout switch prevents tampering with the desired performance level. Built-in balance and ion output monitors verify the presence of balanced, ionized air. A standard power outlet on each Guardian CR2000 blower allows for daisy-chaining up to 10 units.

Unlike some overhead ionizers which link to an external device to provide real-time monitoring, the Guardian CR2000 has sophisticated internal monitoring circuitry which assures that the unit is ionizing and that the balance circuit is functioning.

Features

- Inherently balanced to $0 \pm 10V$
- Ion balance and ion output monitors
- Lockout key switch
- Silicone-free component surfaces
- Integrated emitter point cleaner

Benefits

- Protects even the most sensitive electronic components
- Verifies that the unit is ionizing and balanced
- Helps maintain desired ionization performance level
- ISO 14644-1 Class 4 (Fed Std. 209E Class 10) cleanroom compatibility
- Provides fast, easy maintenance

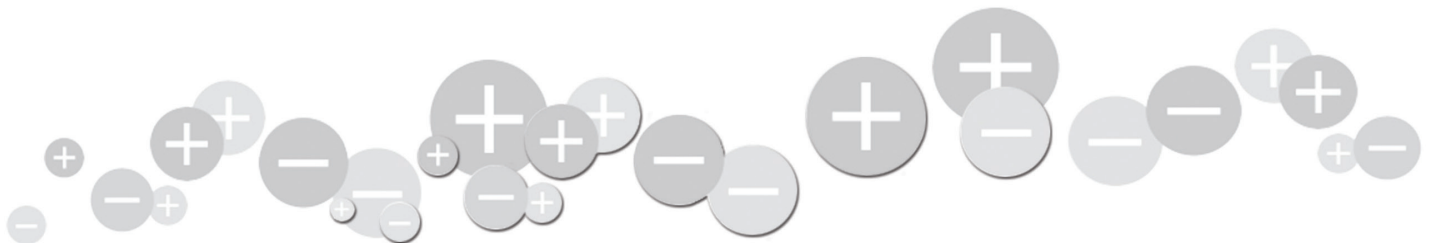

Input Voltage	2-fan 120 VAC, 50/60 Hz, 0.2A; 230 VAC, 50/60 Hz, 0.1A; 3-fan 120 VAC, 50/60 Hz, 0.3A; 230 VAC, 50/60 Hz, 0.15A
Balance	0 ±10V @ 18" from blower face
Discharge	3.0 sec @ 18" center blower position fan high (1000-100V) ¹
Coverage	2' x 3' area 2-fan; 2' x 4' area 3-fan
Cleanroom Class	Meets ISO 14644-1 Class 4; Fed std. 209E Class 10
Emitter Points	Stainless Steel
Controls	3-position key switch OFF, ADJUSTABLE, HIGH; recessed fan speed control
LED Indicators	Ionization Status: green NORMAL, red MAINTENANCE
Air Volume	2-fan 90 cfm fan low, 180 cfm high fan; 3-fan 135 cfm fan low, 270 cfm high fan
Air Velocity	200 fpm (1.0 m/s) fan low; 400 fpm (2.0 m/s) fan high measured @ 18" (46 cm)
Audible Noise	48 dBA fan low; 58 dBA fan high measured @ 2' (61 cm)
Operating Env.	Temperature 32-122°F (0-50°C); humidity 30-70% RH, non-condensing
Ozone	0.02 ppm measured @ 18" above test plate
Power Outlets	Input IEC 320; output IEC 320, allows power connection (daisy-chain) of up to 10 units in series from one power source
Mounting	Adjustable brackets and S hooks provided
Enclosure	Aluminum with glossy white polyurethane finish
Dimensions	31.75W x 4H x 6.75D in. (81 x 10 x 17 cm) 2-fan; 42.75W x 4H x 6.75D in. (109 x 10 x 17 cm) 3-fan
Weight	12 lb (5.5 kg) 2-fan; 15 lb (6.8 kg) 3-fan
Warranty	Two year limited warranty
Certifications	 230V, 50 Hz  120V, 60 Hz

1. Tested in accordance with ANSI/ESD STM3.1-2006.

Ordering Information

4008729	Guardian CR2000 2-fan, 120V, 60 Hz, UL, North America
4008730	Guardian CR2000 2-fan, 230V, 50 Hz, CE, Continental Europe
4008804	Guardian CR2000 2-fan, 230V, 50 Hz, CE, United Kingdom
4008630	Guardian CR2000 3-fan, 120V, 60 Hz, UL, North America
4008705	Guardian CR2000 3-fan, 230V, 50 Hz, CE, Continental Europe
4008805	Guardian CR2000 3-fan, 230V, 50 Hz, CE, United Kingdom
5050542	Overhead Blower Daisy-chain Kit, 10' power cord

Emitter Point Cleaner

The Guardian CR2000 features a built-in emitter point cleaner for each fan. Using the emitter point cleaner takes only seconds. Cleaning the emitter points prevents the build-up of airborne debris. This keeps your Guardian CR2000 working in top form for the life of the unit.

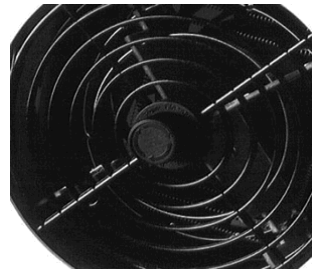

Application-specific Blower Lengths

The Guardian CR2000 Overhead Ionizing Blower comes in either 2-fan or 3-fan chassis lengths. Each length is designed for optimal coverage area and for a variety of applications:

- A 2-fan overhead blower will provide coverage for 2 foot by 3 foot area
- A 3-fan overhead blower covers a 2 foot by 4 foot area

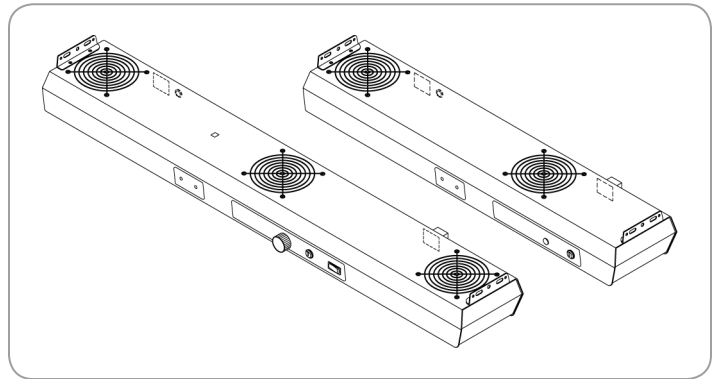

Discharge Time Performance

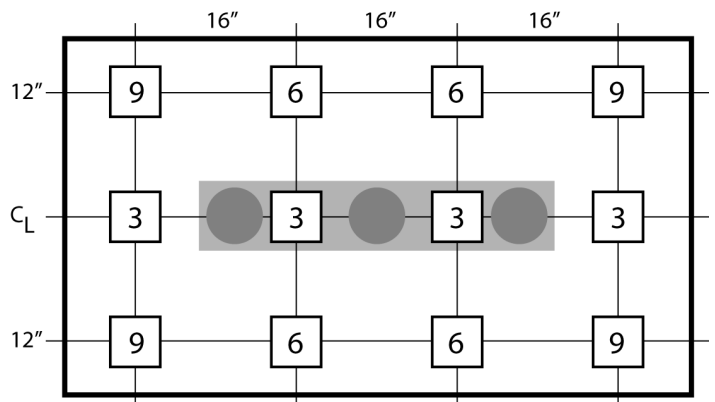

Discharge time in seconds (1000-100V), fan speed set to high; Guardian CR2000 blower 18" from CPM measuring plate; CPM test plate 6" from table; discharge times slightly longer for 230 VAC, 50 Hz unit.

SIMCO IONTM
An ITW Company

DS-Guardian CR2000_V3 - 9/18
© 2018 Simco-Ion
All rights reserved.

Simco-Ion, Technology Group

1601 Harbor Bay Pkwy, Ste 150
Alameda, CA 94502

Tel: +1 (800) 367-2452 (in USA)
Tel: +1 (510) 217-0460

ioninfo@simco-ion.com
www.simco-ion.com