

# Particulate Cleanliness Certification

## *Model 4210 In-line Gas Ionizers*

The 4210u and the 4210uc are designed for use in ultraclean environments, typically Class 1 or better. These units produce so few particles that certification must be completed carefully. This procedure requires a setup that involves the following items:

- A source of CDA or purified N<sub>2</sub>
- Pressure and flow regulation
- A flow regulated vent
- A high-pressure diffuser
- A laser particle counter

### Clean Gas Supply

An important element of the procedure is to use an extremely particle-free gas supply. Because of the cleanliness of the 4210u output, it is necessary to use gas that is >50x cleaner than the Class 1 cleanroom standard (Fed. Std. 209E), providing gas with less than 2 particles per cubic foot ((0.05 m). If such a supply is not available, one can be constructed using the apparatus described in the appendix of this document (see figure 4).

### Gas Handling System

Apply the clean gas (CDA or N<sub>2</sub>) to the 4210u or 4210uc as shown in Figure 1. Connect the apparatus using reinforced PVC fittings employed should be made of stainless steel or Teflon and wiped clean with DI water before assembly. Open the valve and begin to flow gas through the apparatus.

### Setting the Flow Rate

It is necessary to establish a flow rate consistent with normal operation to ensure that the test represents typical operation of the ionizer. Because the laser particle counter operates on only 0.1 cfm of gas, it is necessary to vent most of the gas to the atmosphere.

Use the tee shown in figure 1 as follows:

$F_{input} = 2 \text{ cfm} = 120 \text{ scfh}$

$F_{vent} = 1.9 \text{ cfm} = 114 \text{ scfh}$

This establishes a flow rate to the particle counter of

$F_{counter} = 0.1 \text{ cfm} = 6 \text{ scfh}$

which is the flow rate at which the particle counter is designed to be used.

The Particle Measuring Systems model LPC-HS is recommended for this measurement. It must be preceded by a high-pressure diffuser (model HPD-101), which reduces the pressure of the gas flow to 1 ATM (0 psig) to match the operating requirements of the LPC-HS. The data are recorded using software supplied by the manufacturer.

Note: As an alternative, the Turbo Model 110 can be used, although it records only to 0.1 mm as compared with the LPC-HS, which is sensitive down to 0.05 mm. If the Turbo 110 is employed, the appropriate diffuser is the model HPD-110 and the vent flow should be set to  $F_{vent} = 1 \text{ cfm}$ .

### Blowing Out the 4210

After the gas flow is established, it is necessary to operate the unit at voltage and at flow to blow it clean. After establishing gas flow, power up the unit by plugging it into the AC mains, and run it for at least 2 hours before acquiring any particle data. The unit will continue to improve its operation for several days, but it should operate well within the Class 1 standard of performance after two hours.

### Analyzing the Data

The data are acquired via RS232/C using the manufacturer's Com 200 software, which stores the data

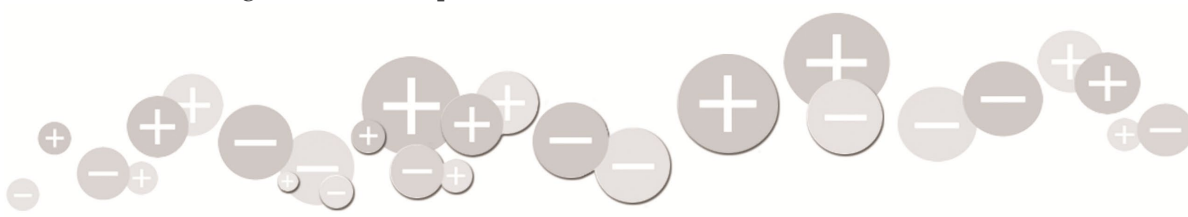

as a file on a PC. This data can be read into Microsoft Excel, Lotus 1-2-3, or other software packages for analysis and plotting. The data includes  $N(d)$ , the number of particles within the size range  $d$ , and the time interval for each observation.

Set the sample time to 10 minutes, so each observation comprises 1 cubic foot of gas. Run the test until adequate statistics have been acquired and store the data to disk as a comma delimited file.

Import the data into an analysis program. In order to do the analysis, calculate the total number of particles observed for each size bin:

$N_i =$  total number of particles of size group  $i$   
 $i = > 0.05 \mu\text{m}, 0.1 \mu\text{m}, 0.15 \mu\text{m}, 0.2 \mu\text{m}, 0.3 \mu\text{m}, 0.5 \mu\text{m}, 0.7 \mu\text{m}, 1 \mu\text{m}$

To compare with the Fed. Std. 209E, it is necessary to calculate an integral distribution by summing the bins.

$$T_{0.050} = N_{0.050} + N_{0.1} + N_{0.15} + \dots + N_1$$

$$P_{0.1} = N_{0.1} + N_{0.15} + N_{0.2} + \dots + N_1$$

And so on...

To obtain the values to plot, simply divide by the total number of samples (the total number of cubic feet of gas analyzed).

$$T_i = P_i / \text{total number of samples}$$

These data points can be graphically compared to the standard for Class 1 performance by comparing to the data values in figure 2 below.

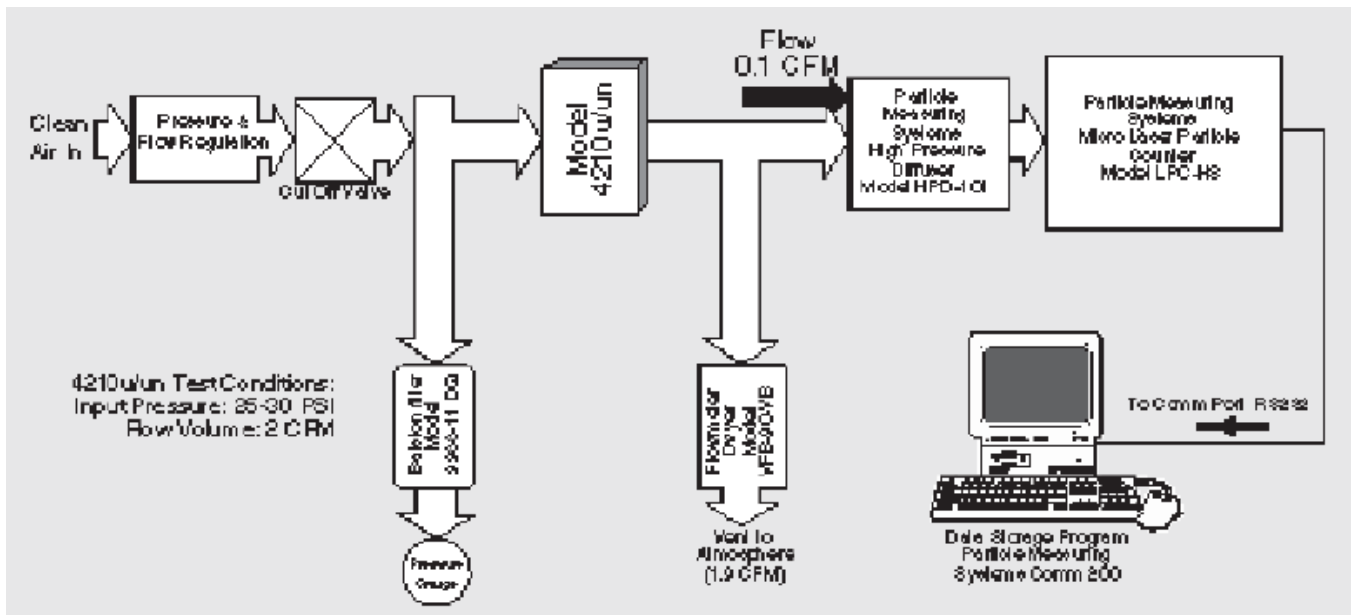

Figure 1. Measurement system for certifying the particulate cleanliness of the 4210u-family

$i =$	0.05	0.1	0.15	0.2	0.3	0.5	0.7	1	
$T_i$	158.49	34.49	14.14	7.51	3.08	1.00	0.48	0.22	$=(.5/i)^{2.2}$

Table 1. Fed. Std. 209E Particulate Limits for a Class 1 Cleanroom

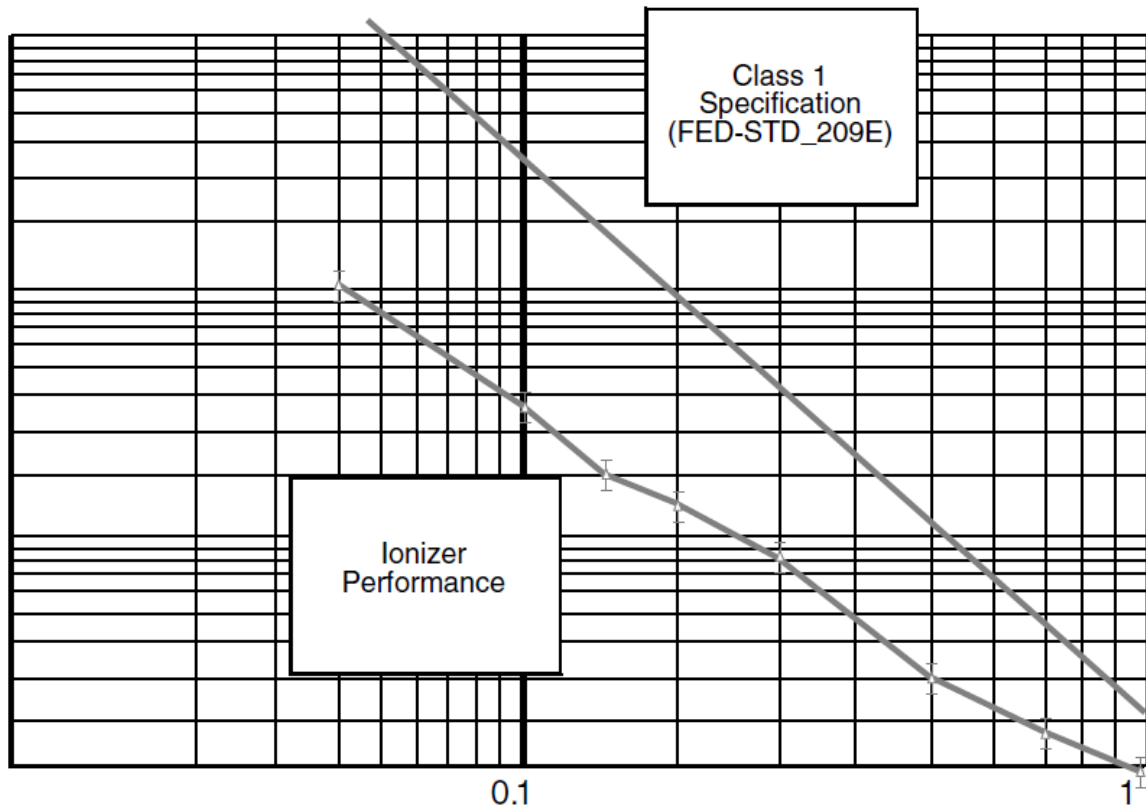

Figure 2. Particulate measurements on a 4210u.

Note: As an example of such data, figure 3 is a data set acquired for a 4210u. As can be seen, the data are well within the Class 1 specification.



© 2020 Simco-Ion  
All rights reserved.

AN-003\_V3 - 11/20