

Performance Test

Aerostat Guardian 3-Fan Overhead Ionizer

Product	AEROSTAT GUARDIAN (3-FAN) OVERHEAD IONIZER
Performance Test	Per ANSI/ESD STM 3.1-2015
Test Conditions	
Test Equipment	Simco-Ion Charge Plate Monitor Model 280A (S/N 66176)
Test Environment	27°C, 49% RH
Test Unit Fan Speeds	High
Distance from Test Unit to CPM	45 cm (18")

The Simco-Ion Aerostat Guardian 3-Fan Overhead Ionizing Blower was tested at the highest speed setting using the appropriate section of ANSI/ESD STM3.1-2015 (see Figure 1. Discharge Time Data and Figure 2. Offset Voltage Data on page 2).

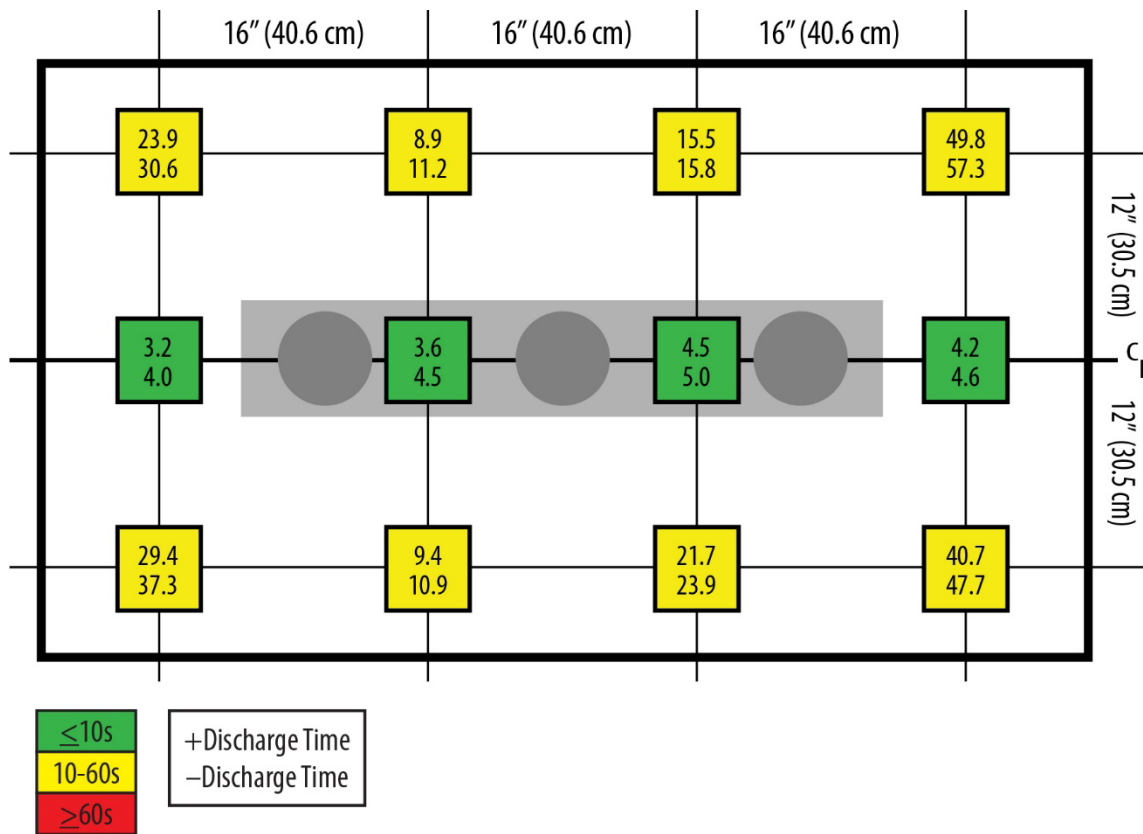

Figure 1. Discharge Time Data (±1000V to ±100V)

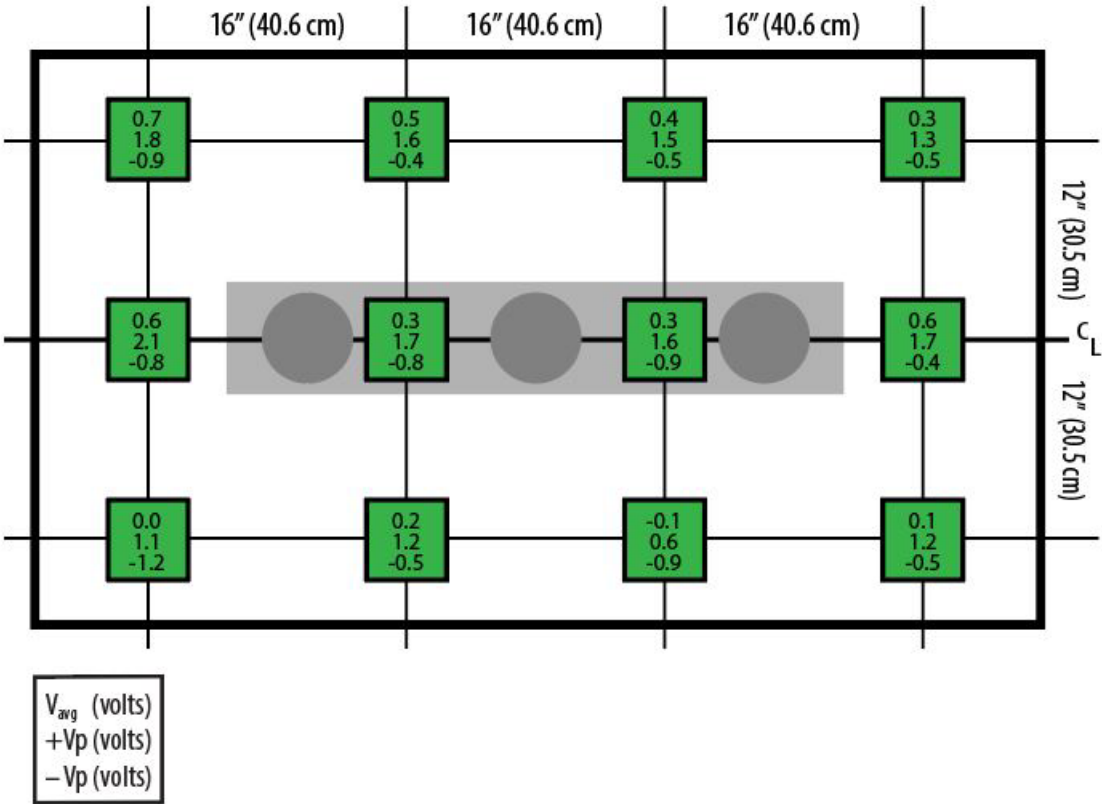
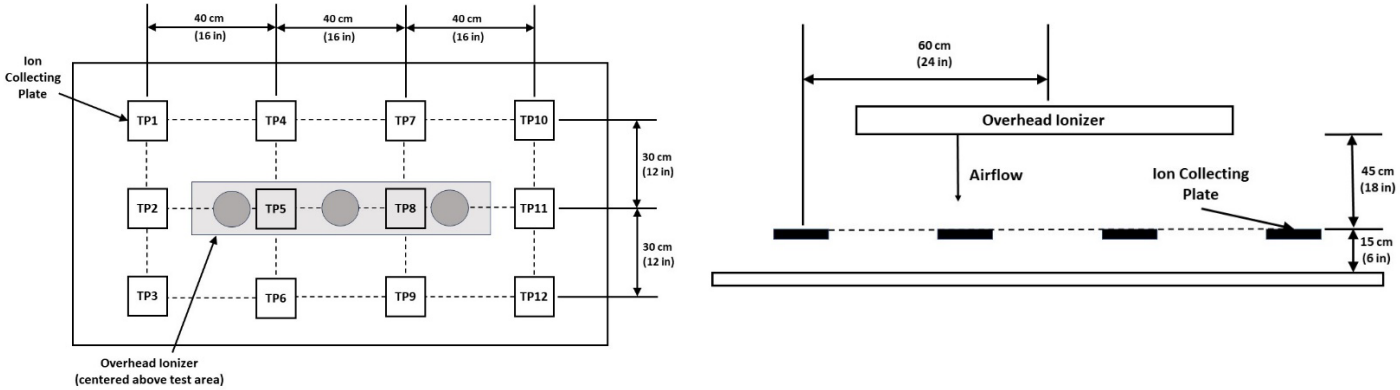

Figure 2. Offset Voltage Data

Example diagrams:



If you have any questions or need assistance, please contact Customer Service.