

Performance Test

Ionizing Blower Model 5941

Product:	Model 5941 Micro Blower
Performance Test:	Per ANSI/ESD STM 3.1-2015
Conditions:	Test equipment: Simco-Ion Charge Plate Monitor Model 280A (S/N: 74697)
	Test environment: 23°C, 40% RH
	Input Power: 24 VDC
	Test unit speeds: High

Offset voltages for all test locations are well within $\pm 3V$

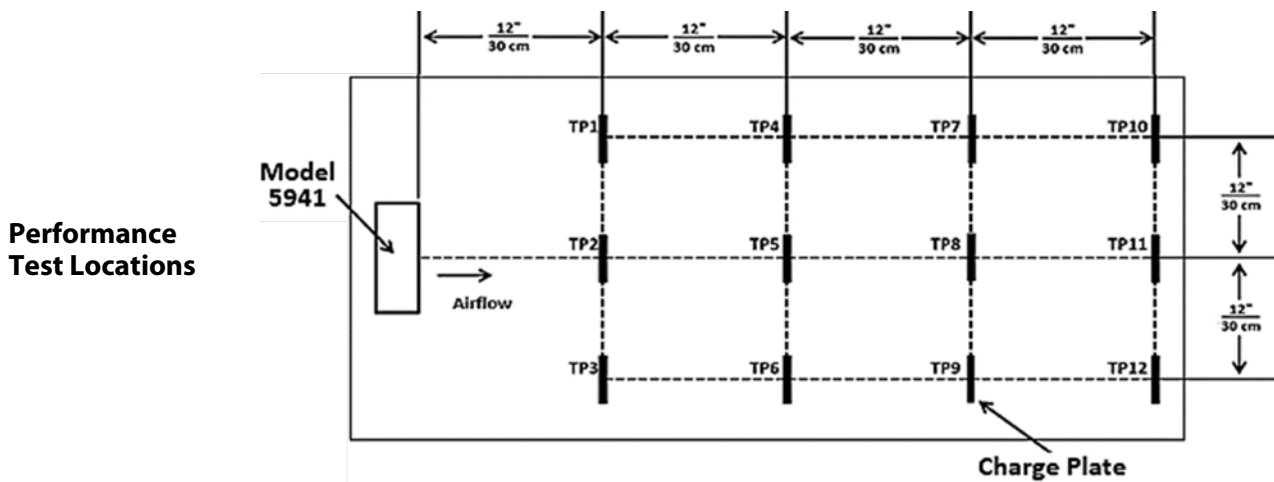

Max Decay Time & Balance (High Fan Speed)

Remark:

1. Top value: max decay time(s) (+/- decay times)
2. Lower value: max balance (v)
3. Yellow cell: decay time >20s

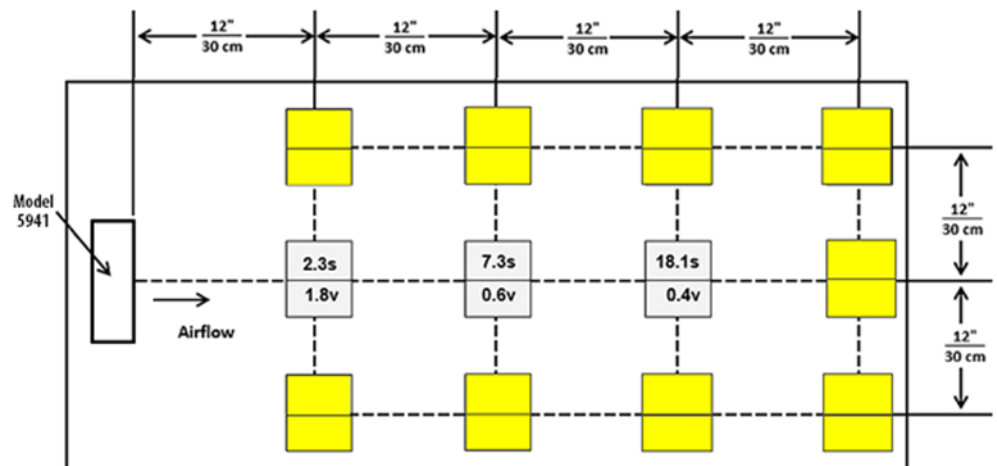

If you have any questions or need assistance, please contact Sales Services.